

EMBOSSED DOT-CODE
MADE UP OF 13 DOTS
(9 DOTS PER CAVITY CODE)
0.45 DEEP - 1.8 DIA
(SHOWN AS CAVITY No.7)

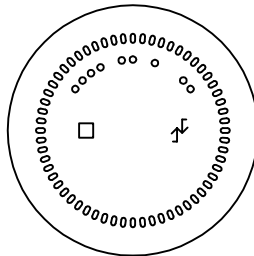

VIEW ON BASE
SHOWING EMBOSSED MARKING.
STANDING AREA EMBOSSED
WITH RADIAL BAR STIPPLE.

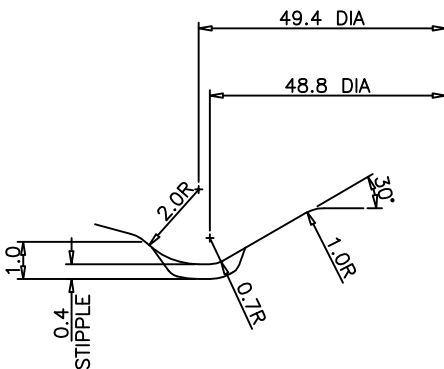

STACKING RING & STIPPLE DETAIL - SCALE 10:1

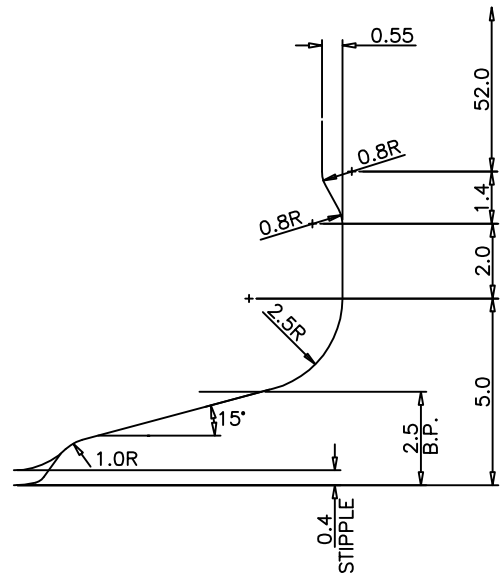

PANEL & BASE DETAIL - SCALE 10:1

SCALE	1:1 (A2)	DESIGNER	CH	190ml Panelled Food Jar - Mk 4			
DATE	05:01:2005	CHECKED	DA				
NECK FINISH	63mm TWIST OFF (FD 138)	A) BASE DOT-CODE ADDED.		(DNA) SN 11/06/12		NECK REF. No. 2K9/P1	
APPROX. WEIGHT	162 g					JOB No. 3932	
FILL POINT	0.0mm down					DRAWING No. B7928A	
CAPACITY TO FILL POINT	199.0 ml					DIMENSIONS IN MILLIMETRES	
CAPACITY TOLERANCE (BULK) ±	3.8ml						
CAPACITY BRIMFULL	199.0 ml						
Note: Filling point measured from top centrally inside neck unless otherwise specified.		Untoleranced dimensions are for mould making guidance only and should be regarded as approximate.		This drawing and the design of the article in the drawing are each the property of Beatson Clark plc, Rotherham. Neither the drawing nor the design shall be copied without the previous written authority of Beatson Clark plc.			